

Type IMC Current Transformer

600 Volt, 10 kV BIL, Indoor

Product Bulletin 1VAP428101-DB



ABB

Product Features

- 600 Volt Indoor
- 10 kV BIL
- 25 through 400 Hertz
- Primary Amperes 50-1000
- 2.5" (64 mm) round window
- Designed for variable ratio applications
- UL Recognized Component; File No. E96461



UL Recognized Component

Application

The IMC is an indoor current transformer used with indicating instruments for switchboards and other industrial applications. It is not recommended for use where a high degree of accuracy is required.

Core and Coils

The ring-type core is assembled within an insulating shell and is toroidally wound with a distributed secondary winding. The whole assembly is then completely enclosed in molded thermoplastic rubber.

Insulation

Thermoplastic rubber insulating material is permanently molded to the core and coil assembly, resulting in a compact unit with excellent mechanical, thermal, and dielectric characteristics.

Secondary Terminals and Cover

The secondary terminals are stud type.

Primary

The large primary opening is adequate for bus bar or cable and is suitable for extra turns as required in multiple ratio applications.

Markings

Polarity markers and current direction arrow are permanently molded into the body of the transformer.

Mounting

The IMC can be flush mounted to a panel or a platform using bolts through any pair of mounting holes in the transformer body. Aluminum mounting feet with hardware are also available for mounting the transformer upright.

Test Reports

IEEE test reports are stored electronically and can be e-mailed in various formats at the time of shipment.

Standards

This unit meets all applicable IEEE and NEMA standards and is a UL Recognized Component.

Instructions for Using the IMC as a Variable Ratio Transformer

The nameplate rating of the IMC current transformer is based on the condition that the primary conductor will be passed once through the transformer opening. The rating can be reduced in even multiples by looping this conductor two or more times through the opening. A transformer rated 200 to 5 amperes will be changed to 50 to 5 amperes if four loops (turns) are made with the primary cable as illustrated in Figure 1.

Changes in rating can also be accomplished by adding or subtracting external turns to or from the secondary winding. Due to the relatively large number of turns in this winding, these changes occur in small steps. Figure 2 shows how turns may be added to the secondary winding by connecting to the "non-polarity" (X2) terminal stud and winding on turns in the direction of the arrow. Figure 3 shows how turns can be subtracted from the secondary winding by connecting to the "polarity" (X1) terminal stud and winding on turns in the direction of the arrow.

Window-type current transformers are frequently used with a 5 ampere ammeter in motor load measurements. The same meter can be used for different size motors by making ratio adjustments as described above. Table 1 can be used to select the desired ratio and to determine the necessary primary and/or secondary turns.

Calculations for this application are illustrated in the example below:

1. Determine the full load current of the motor, i.e., 140 amperes.
2. Determine full scale marking of meter dial, i.e., 0-150% .
3. Calculate the primary current by multiplying the motor full-load current by the full-scale meter marking, then divide by 100.

Example: $140 \times 150/100 = 210$ amperes

4. Use Table 1 to establish the number of primary and secondary turns needed for the particular transformer application.

Examples:

200:5 ampere transformer: Use one turn primary and add two turns to secondary

400:5 ampere transformer: Use two turns primary and add four turns to secondary

Figure 1

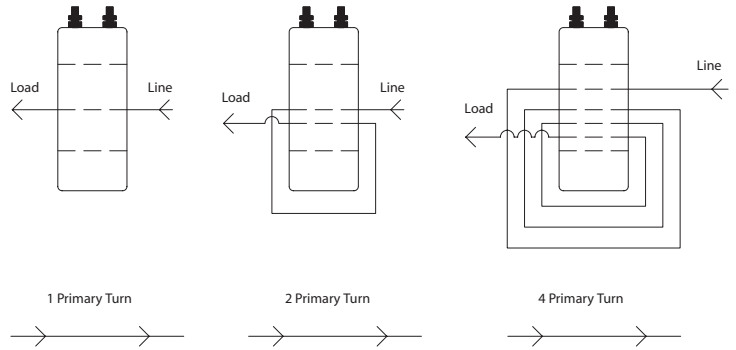

1 Primary Turn		2 Primary Turns		4 Primary Turns	
Nameplate Ratio	Actual Ratio	Nameplate Ratio	Actual Ratio	Nameplate Ratio	Actual Ratio
100:5	100:5	100:5	50:5	100:5	25:5
150:5	150:5	150:5	75:5	150:5	37.5:5
200:5	200:5	200:5	100:5	200:5	50:5
300:5	300:5	300:5	150:5	300:5	75:5
400:5	400:5	400:5	200:5	400:5	100:5
500:5	500:5	500:5	250:5	500:5	125:5
600:5	600:5	600:5	300:5	600:5	150:5
800:5	800:5	800:5	400:5	800:5	200:5

Figure 2: To Add Secondary Turns

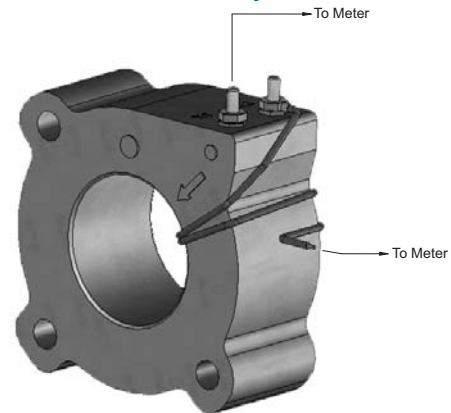

Figure 3: To Subtract Secondary Turns

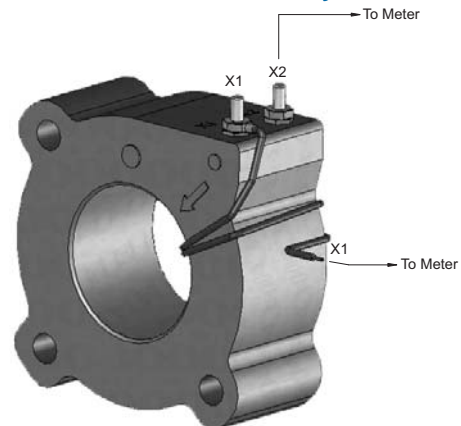
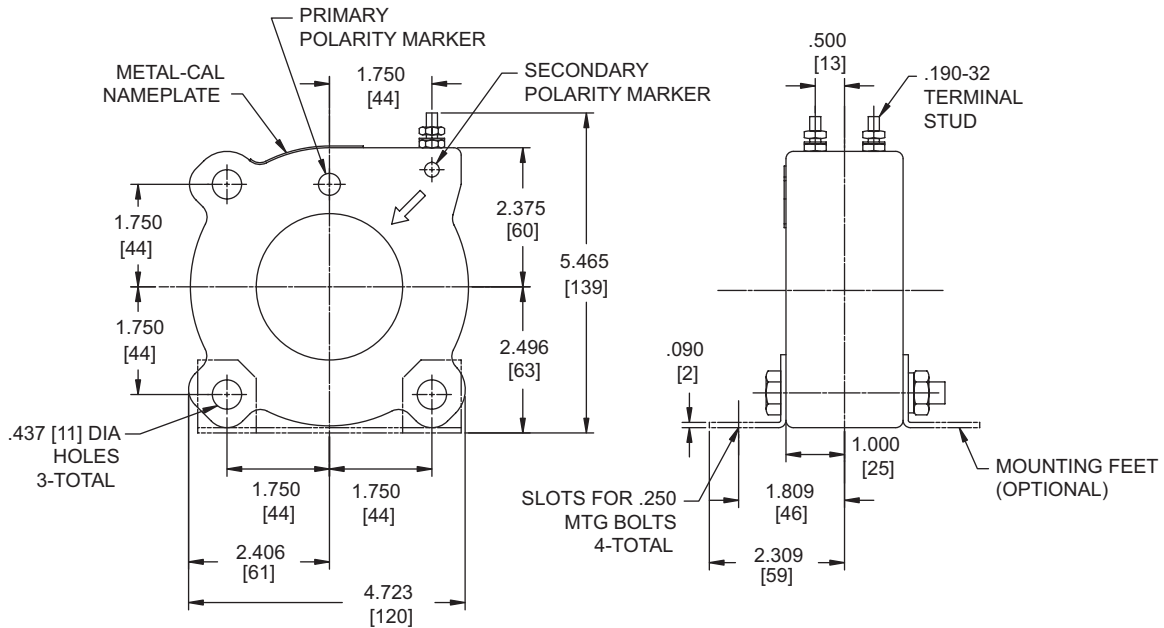

Table 1: To Determine Needed Number of Primary and Secondary Turns

Primary Current for Secondary Current of 5 Amperes								Primary Turns Needed	Secondary Turns Needed	Primary Current for Secondary Current of 5 Amperes								Primary Turns Needed	Secondary Turns Needed
100/5	150/5	200/5	300/5	400/5	500/5	600/5	100/5			150/5	200/5	300/5	400/5	500/5	600/5				
150	200	250	350	450	550	650	1	+ 10	35	47.5	60	85	110	135	160	4	+ 8		
145	195	245	345	445	545	645	1	+ 9	33.7	46.2	58.7	83.7	108.7	133.7	158.7	4	+ 7		
140	190	240	340	440	540	640	1	+ 8	32.5	45	57.5	82.5	107.5	132.5	157.5	4	+ 6		
135	185	235	335	435	535	635	1	+ 7	31.2	43.7	56.2	81.2	106.2	131.2	156.2	4	+ 5		
130	180	230	330	430	530	630	1	+ 6	30	42.5	55	80	105	130	155	4	+ 4		
125	175	225	325	425	525	625	1	+ 5	28.7	41.2	53.7	78.7	103.7	128.7	153.7	4	+ 3		
120	170	220	320	420	520	620	1	+ 4	27.5	40	52.5	77.5	102.5	127.5	152.5	4	+ 2		
115	165	215	315	415	515	615	1	+ 3	26.2	38.7	51.2	76.2	101.2	126.2	151.2	4	+ 1		
110	160	210	310	410	510	610	1	+ 2	25	37.5	50	75	100	125	150	4	0		
105	155	205	305	405	505	605	1	+ 1	23.7	36.2	48.7	73.7	98.7	123.7	148.7	4	- 1		
100	150	200	300	400	500	600	1	0	22.5	35	47.5	72.5	97.5	122.5	147.5	4	- 2		
95	145	195	295	395	495	595	1	- 1	21.2	33.7	46.2	71.2	96.2	121.2	146.2	4	- 3		
90	140	190	290	390	490	590	1	- 2	20	32.5	45	70	95	120	145	4	- 4		
85	135	185	285	385	485	585	1	- 3	18.7	31.2	43.7	68.7	93.7	118.7	143.7	4	- 5		
80	130	180	280	380	480	580	1	- 4	17.5	30	42.5	67.5	92.5	117.5	142.5	4	- 6		
75	125	175	275	375	475	575	1	- 5	26	36	46	66	86	106	126	5	+ 6		
70	120	170	270	370	470	570	1	- 6	25	35	45	65	85	105	125	5	+ 5		
65	115	165	265	365	465	565	1	- 7	24	34	44	64	84	104	124	5	+ 4		
60	110	160	260	360	460	560	1	- 8	23	33	43	63	83	103	123	5	+ 3		
55	105	155	255	355	455	555	1	- 9	22	32	42	62	82	102	122	5	+ 2		
50	100	150	250	350	450	550	1	- 10	21	31	41	61	81	101	121	5	+ 1		
75	100	125	175	225	275	325	2	+ 10	20	30	40	60	80	100	120	5	0		
72.5	97.5	122.5	172.5	222.5	272.5	322.5	2	+ 9	19	29	39	59	79	99	119	5	- 1		
70	95	120	170	220	270	320	2	+ 8	18	28	38	58	78	98	118	5	- 2		
67.5	92.5	117.5	167.5	217.5	267.5	317.5	2	+ 7	17	27	37	57	77	97	117	5	- 3		
65	90	115	165	215	265	315	2	+ 6	16	26	36	56	76	96	116	5	- 4		
62.5	87.5	112.5	162.5	212.5	262.5	312.5	2	+ 5	15	25	35	55	75	95	115	5	- 5		
60	85	110	160	210	260	310	2	+ 4	20.8	29.2	37.5	54.2	70.8	87.5	104.2	6	+ 5		
57.5	82.5	107.5	157.5	207.5	257.5	307.5	2	+ 3	20	28.3	36.7	53.2	70	86.7	103.3	6	+ 4		
55	80	105	155	205	255	305	2	+ 2	19.2	27.5	35.8	52.5	69.2	85.8	102.5	6	+ 3		
52.5	77.5	102.5	152.5	202.5	252.5	302.5	2	+ 1	18.3	26.7	35	51.7	68.3	85	101.7	6	+ 2		
50	75	100	150	200	250	300	2	0	17.5	25.8	34.2	50.8	67.5	84.2	100.8	6	+ 1		
47.5	72.5	97.5	147.5	197.5	247.5	297.5	2	- 1	16.7	25	33.3	50	66.7	83.3	100	6	0		
45	70	95	145	195	245	295	2	- 2	15.8	24.2	32.5	49.2	65.8	82.5	99.1	6	- 1		
42.5	67.5	92.5	142.5	192.5	242.5	292.5	2	- 3	15	23.3	31.7	48.3	65	81.7	98.3	6	- 2		
40	65	90	140	190	240	290	2	- 4	14.2	22.5	30.8	47.5	64.2	80.8	97.5	6	- 3		
37.5	62.5	87.5	137.5	187.5	237.5	287.5	2	- 5	13.3	21.6	30	46.7	63.3	80	96.7	6	- 4		
35	60	85	135	185	235	285	2	- 6	17.1	24.3	31.4	45.7	60	74.3	88.6	7	+ 4		
32.5	57.5	82.5	132.5	182.5	232.5	282.5	2	- 7	16.47	23.6	30.7	45	59.3	73.6	87.9	7	+ 3		
30	55	80	130	180	230	280	2	- 8	15.7	22.9	30	44.3	58.6	72.9	87.1	7	+ 2		
27.5	52.5	77.5	127.5	177.5	227.5	277.5	2	- 9	15	22.1	29.3	43.6	57.9	72.1	86.4	7	+ 1		
25	50	75	125	175	225	275	2	- 10	14.3	21.4	28.6	42.9	57.1	71.4	85.7	7	0		
50	66.7	83.3	116.7	150	183.3	216.7	3	+ 10	13.6	20.7	27.9	42.1	56.4	70.7	85	7	- 1		
48.3	65	81.7	115	148.3	181.7	215	3	+ 9	12.9	20	27.1	41.4	55.7	70	84.3	7	- 2		
46.7	63.3	80	113.3	146.7	180	213.3	3	+ 8	12.1	19.3	26.4	40.7	55	69.3	83.6	7	- 3		
45	61.7	78.3	111.7	145	178.3	211.7	3	+ 7	11.4	18.6	25.7	40	54.3	68.6	82.9	7	- 4		
43.3	60	76.7	110	143.3	176.7	210	3	+ 6	14.4	20.7	26.9	39.4	51.9	64.3	76.9	8	+ 3		
41.7	58.3	75	108.3	141.7	175	208.3	3	+ 5	13.8	20.1	26.3	38.8	51.3	63.7	76.3	8	+ 2		
40	56.7	73.3	106.7	140	173.3	206.7	3	+ 4	13.1	19.4	25.6	38.1	50.6	63.1	75.6	8	+ 1		
38.3	55	71.7	105	138.3	171.7	205	3	+ 3	12.5	18.8	25	37.5	50	62.5	75	8	0		
36.7	53.3	70	103.3	136.7	170	203.3	3	+ 2	11.9	18.2	24.4	36.9	49.4	61.9	74.4	8	- 1		
35	51.7	68.3	101.7	135	168.3	201.7	3	+ 1	11.2	17.6	23.8	36.3	48.8	61.2	73.8	8	- 2		
33.3	50	66.7	100	133.3	166.7	200	3	0	10.6	16.9	23.1	35.6	48.1	60.6	73.1	8	- 3		
31.7	48.3	65	98.3	131.7	165	198.3	3	- 1	12.8	18.3	23.9	35	46.1	57.2	68.3	9	+ 3		
30	46.7	63.3	96.7	130	163.3	196.7	3	- 2	12.2	17.7	23.3	34.4	45.5	56.7	67.8	9	+ 2		
28.3	45	61.7	95	128.3	161.7	195	3	- 3	11.7	17.2	22.8	33.9	45	56.1	67.2	9	+ 1		
26.7	43.3	60	93.3	126.7	160	193.3	3	- 4	11.1	16.7	22.2	33.3	44.4	55.6	66.7	9	0		
25	41.7	58.3	91.7	125	158.3	191.7	3	- 5	10.5	16.1	21.7	32.8	43.9	55	66.1	9	- 1		
23.3	40	56.7	90	123.3	156.7	190	3	- 6	10	15.5	21.1	32.2	43.3	54.4	65.5	9	- 2		
21.7	38.3	55	88.3	121.7	155	188.3	3	- 7	9.4	15	20.5	31.7	42.8	53.9	65	9	- 3		
20	36.7	53.3	86.7	120	153.3	186.7	3	- 8	11.5	16.5	21.5	31.5	41.5	51.5	61.5	10	+ 3		
18.3	35	51.7	85	118.3	151.7	185	3	- 9	11	16	21	31	41	51	61	10	+ 2		
16.7	33.3	50	83.3	116.7	150	183.3	3	- 10	10.5	15.5	20.5	30.5	40.5	50.5	60.5	10	+ 1		
									10	15	20	30	40	50	60	10	0		
									9.5	14.5	19.5	29.5	39.5	49.5	59.5	10	- 1		
									9	14	19	29	39	49	59	10	- 2		
									8.5	13.5	18.5	28.5	38.5	48.5	58.5	10	- 3		

Unit Dimensions



Approximate weight is 4 lbs.

Note: Metric dimensions are displayed in [mm].

Selection Guide

Primary Ampere Rating	Rating Factor		IEEE Metering Accuracy	Style Number
	30° C	55° C		
50	2.0	1.5	2.4B-0.1	7524A98G11
100	2.0	1.5	1.2B-0.1	7524A98G01
150	2.0	1.5	1.2B-0.2	7524A98G02
200	2.0	1.5	0.6B-0.1	7524A98G03
250	2.0	1.5	0.6B-0.1	7524A98G04
300	2.0	1.5	0.6B-0.5	7524A98G05
400	2.0	1.5	0.6B-0.5	7524A98G06
500	2.0	1.5	0.3B-0.2	7524A98G07
600	1.5	1.2	0.3B-0.2	7524A98G08
800	1.33	1.0	0.3B-0.5	7524A98G09
1000	1.0	0.75	0.3B-0.5	7524A98G10

Additional styles available upon request. Contact your ABB Sales Representative or call +1-252-827-3212 for more information.

Optional Accessories

- Mounting feet - set of two 9628A05G01



ABB Inc.
Highway 43 North
Pinetops, NC 27864
Tel: +1-252-827-3212
www.abb.com/mediumvoltage